

LIVALL

PikaBoo⚡t 2 User Manual

Version: V1.2

Revised Date: 18 October 2024

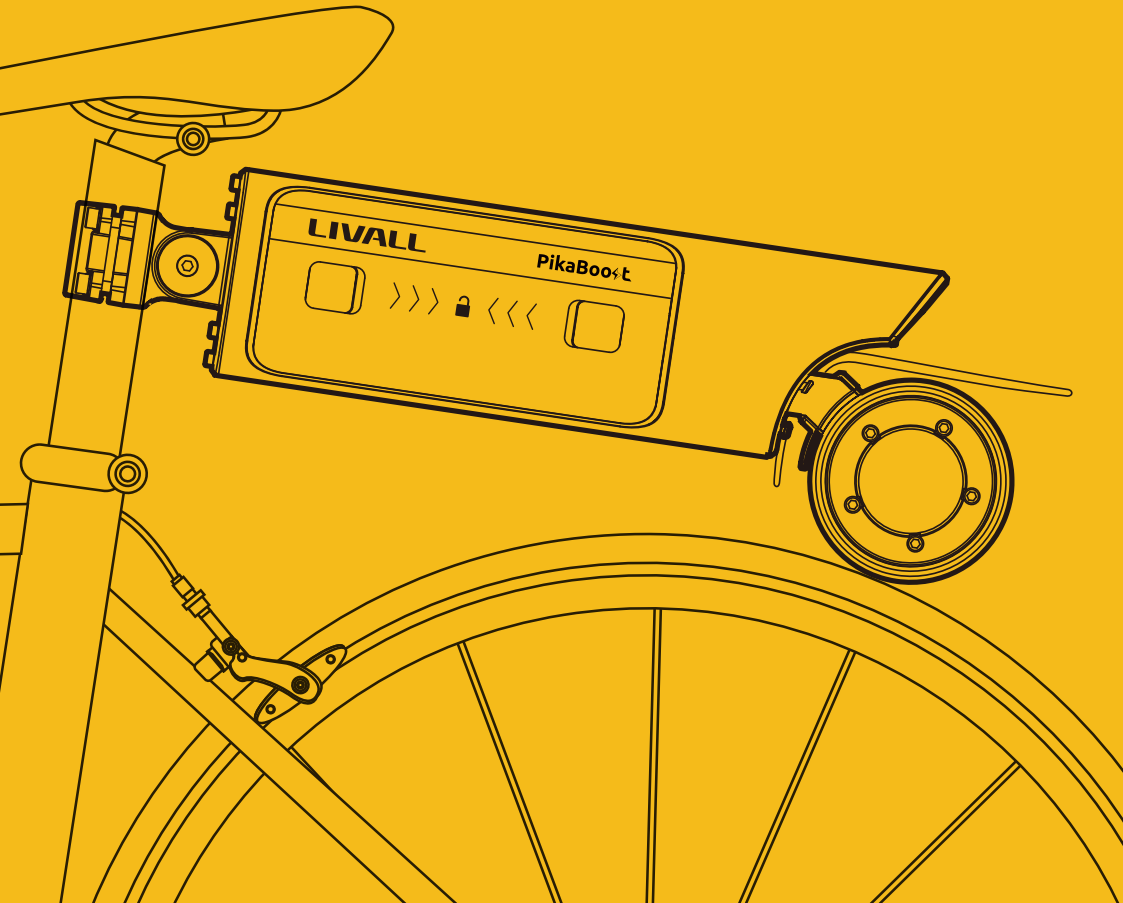

Nothing beats the joy of riding!
We want you to get out there and have fun.
But, first...
please read the manual.



If you have any more questions, check out our instructional videos or contact our support team via email.

Contact us for help here:
Website: www.livall.com
Email: user@livall.com

Contents

Instructions for Use	01
Pre-ride Check List	03
Important Safety Information	04
Basic Information	08
Part Name	08
Compatible Parameter of the Seat Post	09
Specification	10
Package Content	10
Preparation Work	11
Put the Battery Case in the PikaBoost House	11
Download LIVALL Riding APP	11
APP Pairing	12
First Installation of PikaBoost	16
Install the PikaBoost	16
Check the Fit Between the PikaBoost and the Bicycle	17
Install the PikaBoost	18
Recharging and Power Supply via PikaBoost	19
Recharging the PikaBoost	19
Power Supply with PikaBoost	20
Selection and Switching of the Riding Modes	21
Select the Riding Modes	21
Switch the Riding Modes	26

Installation and Usage of the Remote Controller	27
Functioning Principle	27
Matching Method	28
Matching Method	28
Check the Mounting Position	30
Usage	32
Battery Replacement	32
Safety Information	33
Warranty Policy	34
Safe Operating Tips	35
Local Laws	36
Warning	37

This manual is not intended as a detailed user, service repair, or maintenance manual.
Please consult LIVALL technicians for service, repairs, or maintenance.

Instructions for Use

This manual is not intended as a detailed user, service repair, or maintenance manual. Please consult LIVALL technicians for service, repairs, or maintenance.

The Basics of Reading

- Whether you're new to cycling or an experienced rider, please take the time to read the Manual before using PikaBoost for your cycling adventures. You can scan the QR code on the first page of the Manual to watch the related instructional videos. We will keep updating the content of this manual, so please always refer to the latest version for accurate information.
- If your PikaBoost will be used by children, it's really important to make sure they know all the safety information and how to operate it correctly. And don't forget, parents should always be there to supervise them and make sure they stay safe during their ride. Safety first!

Local Laws

The regulations regarding the use and operation of E-bike conversion kits may vary depending on the country, state/province, and city of residence. In many cases, the regulations for using E-bike conversion kits are the same as those for regular bicycles.

However, each jurisdiction may have laws regarding permits and regulations for E-bike conversion kits, areas where they can be ridden, minimum riding age, or required equipment (such as helmets).

Riders are responsible for understanding the local regulations for using such products and complying with them.

A Note About Warnings

- As you read this manual, you'll see gray warning boxes like this:

WARNING!

Text in a gray box with the safety alert symbol will warn you about a situation or behavior that could cause severe injury or death.

- The reason for these warnings is that we don't want you - or your loved ones, or your kit - to get hurt. So please pay attention to the warnings. It's our way of letting you know we care about your safety.

On Your First Ride

- Please be VERY CAREFUL when using the PikaBoost for the first time on your bike, as it significantly increases the speed compared to a regular bicycle in AUTO cycling type. Before starting your first ride, make sure to switch off or put PikaBoost on standby mode and find an open space. Avoid pedaling hard as soon as you start with PikaBoost engaged, as the bike will continue to accelerate, potentially catching you off guard. However, after a few rides, you will begin to appreciate the thrilling cycling experience that PikaBoost provides.

*Note that this is a general manual. LIVALL reserves the right to make changes to products and designs. The products you own may not have the same style as the pictures shown in this manual.

Pre-ride Check List

Before Your Each Ride

Before starting your ride, perform a safety check on a flat surface away from traffic. If any part fails the safety check, have it inspected and repaired before using the PikaBoost.

Safety Check	Steps Involved
<input type="checkbox"/> Seat Post	<ul style="list-style-type: none">• Check if the seat post is firmly locked.
<input type="checkbox"/> Bracket	<ul style="list-style-type: none">• Check if the bracket is securely fastened to the bicycle seatpost and if there is any looseness or displacement.• Check if the orientation of the bracket aligned with the rear tire.• Check if the screws on the bracket have come loose.
<input type="checkbox"/> Locking screws	<ul style="list-style-type: none">• Check if the locking screws is fully tightened.
<input type="checkbox"/> Tire	<ul style="list-style-type: none">• Check if the PikaBoost tire and the bicycle rear tire fit properly.
<input type="checkbox"/> Battery Case	<ul style="list-style-type: none">• Check if the screws on the battery case have come off or are about to come off.• Check if the PikaBoost body cover is fully closed.• Check if the battery level is sufficient for this ride.
<input type="checkbox"/> Bling remote controller	<ul style="list-style-type: none">• Check if the brake controller is working properly. (By pressing the brake handle, check if the brake indicator lights up and if the tail light respond with the corresponding flashing light.)• Check if the magnets installed on the rear brake handle and front brake handle (if any) are securely attached, and if the magnets are misaligned or detached.• Check if the installation position of the brake sensor can timely detect the magnets.• Check if the brake receiver can function properly and if it can switch between riding mode and standby status smoothly.

WARNING!

Regularly inspecting and adjusting PikaBoost can effectively ensure your cycling safety.

Important Safety Information

This product is an e-bike conversion kit equipped with a lithium battery as a power source. Before using PikaBoost for cycling, please read and comply with the following instructions carefully.

- **PikaBoost Can't Protect you in an Accident**

When using PikaBoost for cycling, the most common injury is falling down, which could be due to not switching the riding mode of PikaBoost to standby mode when stopping. PikaBoost can not avoid being damaged after a fall. If you experience any collision, impact, or accident, please carefully check yourself for injuries, and then before using PikaBoost for cycling again, please contact LIVALL technicians for online guidance to thoroughly inspect your PikaBoost.

- **Know Your Limits**

If you attempt to use PikaBoost beyond your ability range while cycling, there may be a certain level of danger involved. Please understand your cycling skill level beforehand and refrain from using it beyond your personal capabilities.

- **Lifespan**

PikaBoost is not indestructible, and its parts will not last forever. The PikaBoost is made to withstand the stress of "normal" riding because those stress is well-known and understood.

However, we cannot predict the forces that might occur if you use your PikaBoost in competition, if you ride in extreme conditions, if it is involved in a crash, if it is used for rentals or commercial purposes, or if it is used in other ways that apply high stress of fatigue loads.

With damage, the life of any part can be drastically reduced and may fail without warning. The safe life of a part is determined by its construction, materials, use, maintenance, rider weight, bicycle type, speed, terrain, and environment (humidity, salinity, temperature, etc.), so it is not possible to give an accurate timetable for replacement.

Any crack, scratch, or change of color in a high-stress area indicates the part (including the bracket and housing) has reached the end of its life and should be replaced. If you are not sure or you don't feel comfortable inspecting or repairing your PikaBoost, consult LIVALL technicians. Regular maintenance, frequent inspections, and frequent replacement of parts are necessary for safe use, high-performance PikaBoost.

⚠ WARNING!

PikaBoost is subjected to wear and high stress. Different materials and parts may react to wear or stress fatigue in different ways. If the design life of a part has been exceeded, it may suddenly fail.

- **Handle with Care**

PikaBoost components are especially vulnerable. The wiring, battery case, and brake controller of PikaBoost can be easily damaged if handled incorrectly.

- **Think Safety**

Stay tuned to your environment and avoid dangerous situations which are usually obvious (traffic, obstacles, drop-offs, and so on), but sometimes are not. Some of the high-risk stunts and jumps seen in magazines or videos are very dangerous, even skilled athletes get severe injuries when they crash (and they do crash).

Modifications to your PikaBoost can make it unsafe. Each part of your new PikaBoost has been carefully chosen and approved. The safety of accessory or replacement parts and especially how those parts attach and interface with other parts of the PikaBoost is not always apparent. For this reason, you should only replace parts with original equipment or parts that are approved. If you are not sure what parts are approved, ask LIVALL technicians.

Examples of modifications include this partial list:

- Physically altering existing parts (sanding, filing, drilling, etc.)
- Purchasing and using lithium batteries that have not been approved by LIVALL
- Adding a motor or engine
- Installing accessories
- Changing parts

⚠ WARNING!

Failure to compatibility, properly install, operate, and maintain any component or accessory can result in serious injury or death.

⚠ WARNING!

Changing the components with other than genuine replacement parts may compromise the safety of your PikaBoost and void the warranty. Check with LIVALL technicians/retailers before changing the components.

⚠ WARNING!

Any accessory or component attached to, on, or near a rotating wheel poses a risk of contact-ing or stopping the wheel, leading to a crash resulting in serious injury or death. Before every ride check to ensure that all such accessories and components of PikaBoost are securely mounted to your bicycle.

⚠ WARNING!

In non-riding conditions, be sure to use the APP or brake controller to switch PikaBoost to standby status to avoid triggering the PikaBoost motor and providing assistance to the bicycle while walking, which can result in serious injury or death.

New components or accessories could interfere with the operation of your PikaBoost use, including the power assistance level, brake sensitivity, and the tightness of the bracket. Always verify that any new product your purchase for your PikaBoost does not interfere with these functions.

⚠ WARNING!

If your PikaBoost's controls are impaired or compromised due to the use of incompatible bikes, accessories or components, the PikaBoost may stop unexpectedly, or you may lose control of your bicycle and crash, resulting in serious injury or death.

⚠ WARNING!

If your PikaBoost's controls are impaired or compromised due to the use of incompatible bikes, accessories or components, the PikaBoost may stop unexpectedly, or you may lose control of your bicycle and crash, resulting in serious injury or death.

These include but are not limited to.

- An unauthorized or incorrectly mounted fender can cause the bike to stop suddenly.
- Mounting PikaBoost on an incompatible bicycle seat post (material, shape, and diameter) may cause the seat post to break.
- When using the assistance riding mode, installing PikaBoost on a rear tire with a smooth tread pattern may result in slippage.

⚠ WARNING!

Always take the battery case out of the PikaBoost and store it in a safe place when the PikaBoost is not in use. Unauthorized use of your PikaBoost by others may result in serious injury or death.

- **Charge the Battery Case**

The battery case is supplied partially charged. For best performance, fully charge the battery case before riding with your PikaBoost.

⚠ WARNING! Be safe. Follow these safety warnings when charging your battery:

- Charge the PikaBoost in a well-ventilated environment at a suitable temperature. Charging under intense sunlight, high-temperature conditions, or extremely cold environments is strictly prohibited.
- Before charging, ensure that the charging interface is free from water stains and foreign objects and that the power cable is not damaged.
- During the charging process, if there is any unusual smell or the charger's casing becomes overheated, please immediately stop charging and consult LIVALL technicians for repairs.
- During the charging process, always pay attention to the charging status and do not leave it unattended for a long time. After the charging is complete, the power indicator lights are all on, and the power supply should be disconnected in time. It is prohibited to connect the charger to an AC power source for a long time without charging.

Basic Information

Part Name

PikaBoost 2

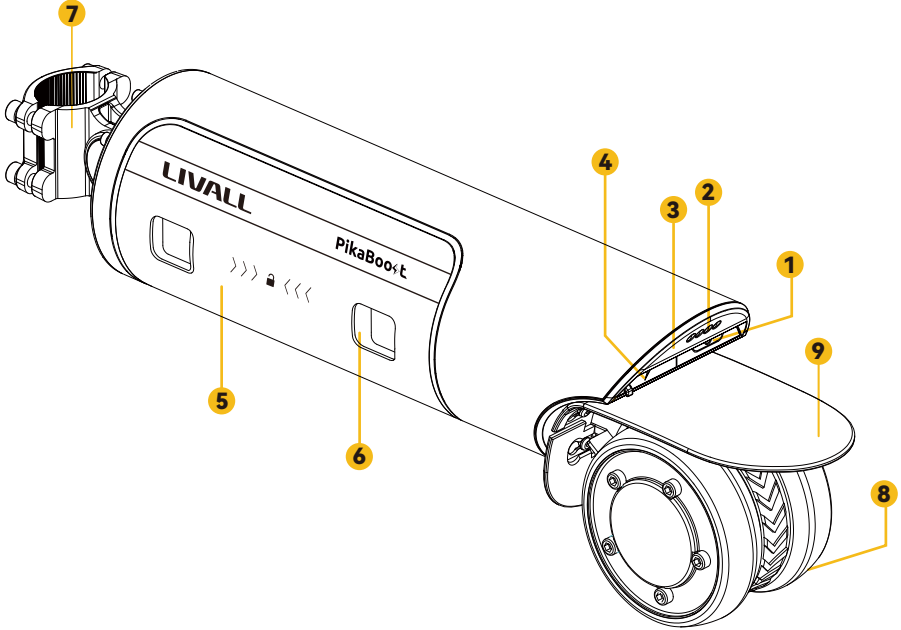

1 Power Button

Power on/off

4 USB-C Charging Port

7 Locking Screw

installing/dismantling the PikaBoost.

2 Power Indicator

Light up and display battery level after powering on.

5 Housing Lid

8 Tire

3 Tail Light

Display different lights when braking/cycling.

6 Release Buckle

Use a two-finger press to open/lock the housing lid.

9 Mudguard

Compatible Parameter of the Seat Post

- **Seat Post of the Bicycle**

Compatible shapes: Round & D Shape

Compatible diameter: $\Phi 25.4 \sim 34.9\text{mm}$

****Not compatible with carbon seat posts****

- **The Rear Tire of the Bicycle**

The tread pattern of the rear tire of a bicycle can affect the friction noise between the PikaBoost tire and the rear wheel of the bicycle.



⚠ WARNING!

When riding in assistance mode, if the tread of the bicycle tire is too smooth, the bike is prone to slipping during uphill climbs, posing a certain safety risk. To enhance the climbing performance of your bicycle, please choose a rear tire for PikaBoost that has an anti-slip effect.

Specification

Weight	2kg / 4.41lbs
Dimension	436*89*131mm
Top Speed	32km/h (can vary between contries)
Power	250W
Rated capacity	7.2Ah / 10.2Ah
Charging Port	Type-C
Waterproof Level	IPx5

Package Content

Check that the package is complete and undamaged.

Your PikaBoost package contains the following items:

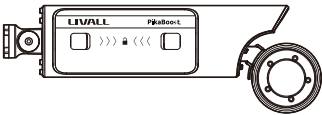

1. PikaBoost



2. Remote Controller



3. Mudguard



4. Fixed cover



5. Wrench



6. Type-C Cable



7. Quick Guide

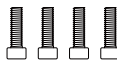

8. Anti disassembly screws x4

Preparation Work

Put the Battery Case in the PikaBoost House

***Batteries are loaded in the battery case.**

To install the battery cells into the battery case, please read the instructions (manual and video) related to the battery cells before installation. Install them strictly following the steps provided on the official website.

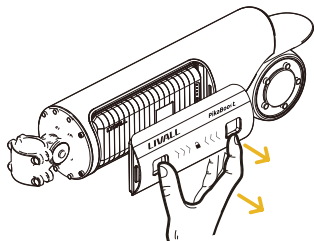

1. Press the buckle to open the house lid.

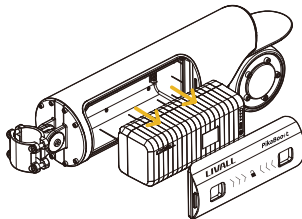

2. Put the battery case into the PikaBoost housing.

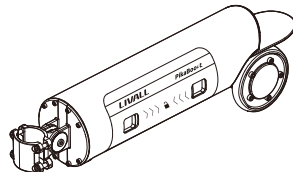

3. Cover back the house lid on the PikaBoost.

Check the tightness of the house lid:

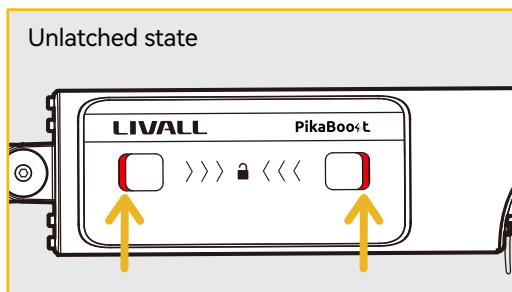
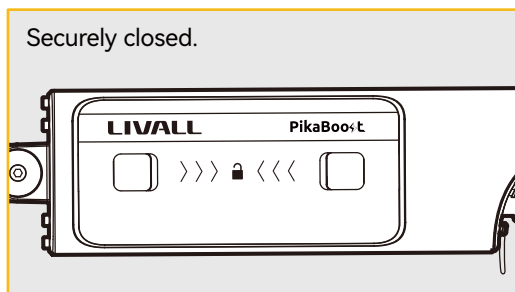

Note:

1. Before riding, ensure that the house lid is fully closed. This prevents the lid from falling off on bumpy roads, which can cause water damage to the PikaBoost device on rainy days.
2. If water gets into the PikaBoost device, please take out the battery case immediately and dry the PikaBoost device and battery case before using. If the device does not turn on, consult LIVALL technicians for help.



Download LIVALL Riding APP

Scan the QR code to download the LIVALL Riding APP. You can also search for "LIVALL Riding" in APP Store/Google Play and download it.

APP Pairing

To use the PikaBoost, open the LIVALL Riding APP, and pair it with the PikaBoost device before the first use. Follow these steps:

1. Turn on the PikaBoost

- Long press the power button on PikaBoost until the power indicator light turns on a tone signal sounds.

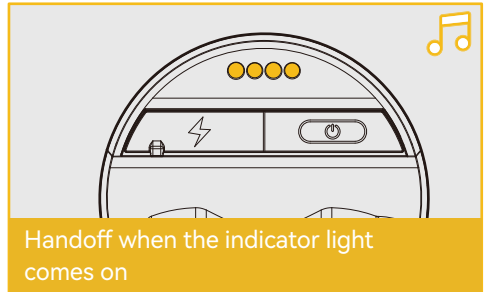
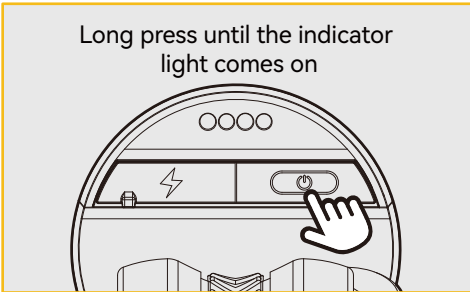

Note: If the power indicator light flashes no light after a 3-second hold indicates a low battery. Please charge the PikaBoost in time.

2. Open LIVALL Riding APP

- On the APP page, click "Device" on the bottom menu bar, scroll down the page, click the "PikaBoost" button, and establish a connection by bringing the phone close to the PikaBoost device.

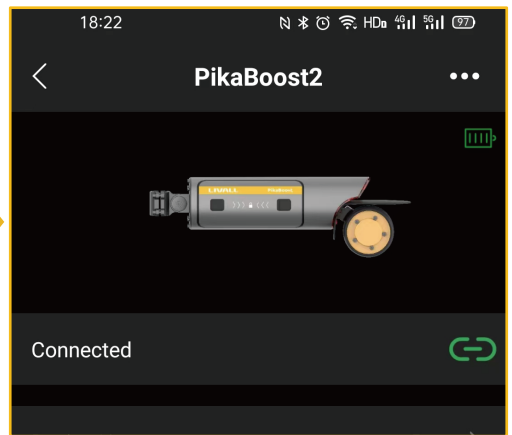
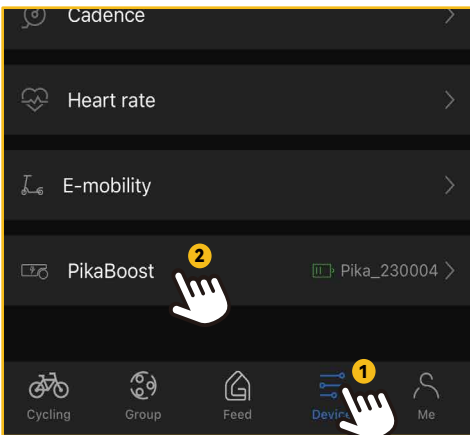

Note: Before connecting, make sure your phone's Bluetooth is turned on.

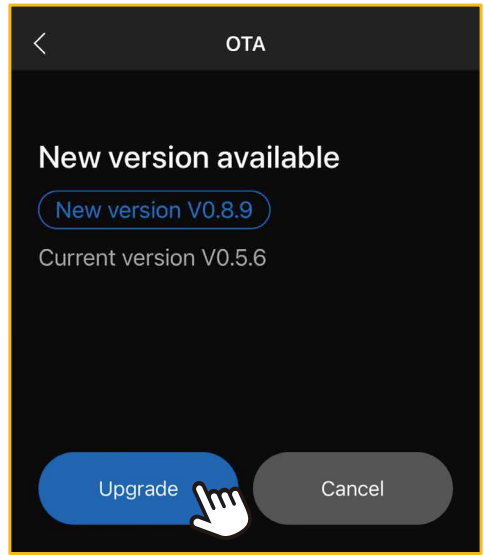
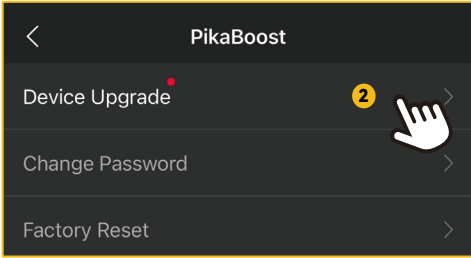
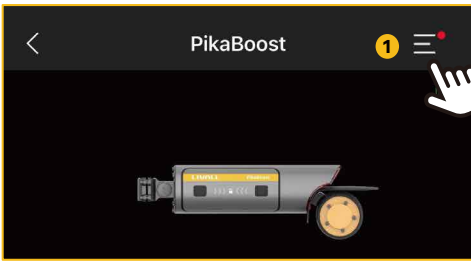

1. A red dot appears in the top right corner, indicating a new version update is available. Tap to upgrade pikaboost,click Device Upgrade.

2. Tap "Upgrade" to update pikaboost.

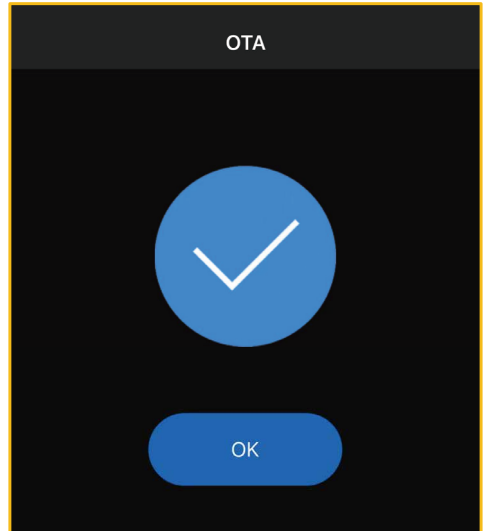
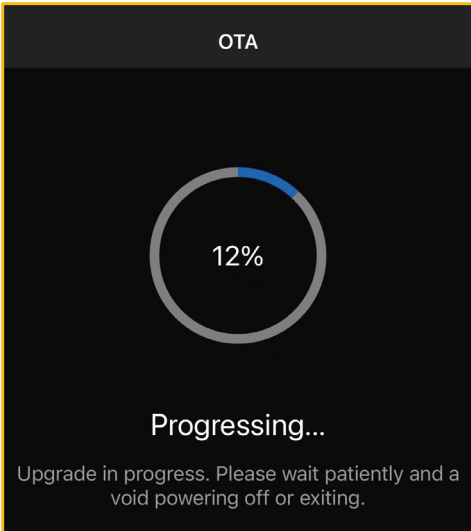

3. Do not leave this page during upgrade.

4. After the upgrade is complete, pikaboost will power off. You will need to turn pikaboost back on.

Note: If the upgrade fails, you can restart pikaboost and try the upgrade again.

3. Change the connection password

- The default connection password is 000000 after the first APP connection. It is recommended to change the connection password of your PikaBoost to avoid unauthorized connections.

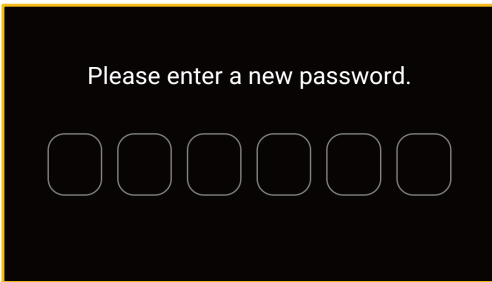
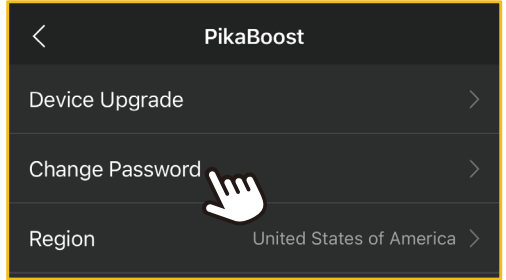
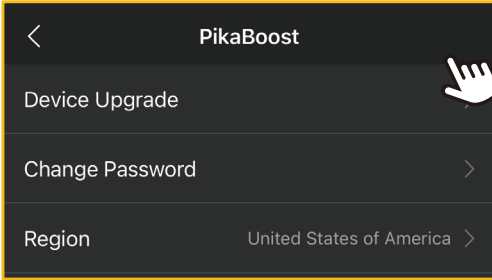

4. Change the device name

- It is recommended to rename your PikaBoost device on the APP to easily identify it among others.

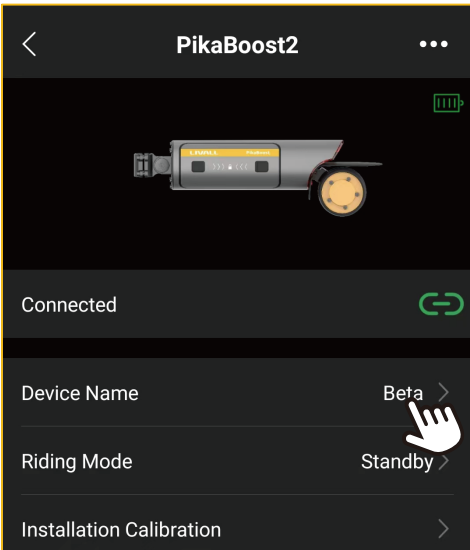

5. Select Country/Region

- Before using the PikaBoost, please select your country/region in the APP. PikaBoost will provide you with the maximum speed limit and riding modes according to the country/region you select.

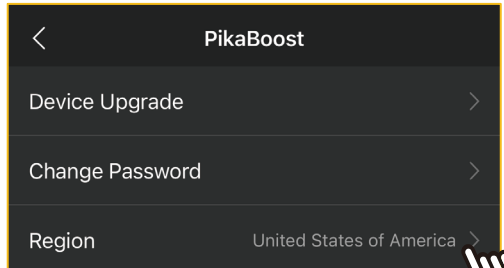

⚠ WARNING!

If your actual riding location is different from the selected country/region, your riding behavior may violate local traffic laws and regulations. The manufacturer, seller, and distributor are not responsible for any consequences arising from this.

6. Lift up the PikaBoost Wheel.

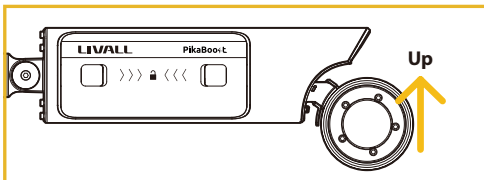
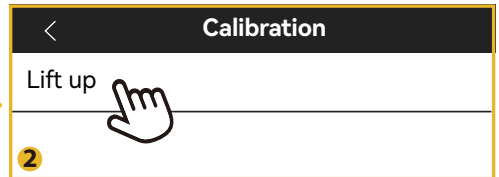
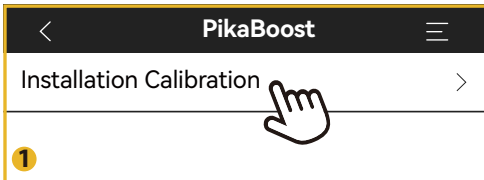

Before installing the device, please open the LIVALL Riding APP, enter the PikaBoost page, click "Install Calibration-Lift Up", and lift the PikaBoost wheel until it is automatically completed.

First Installation of PikaBoost

Install the PikaBoost

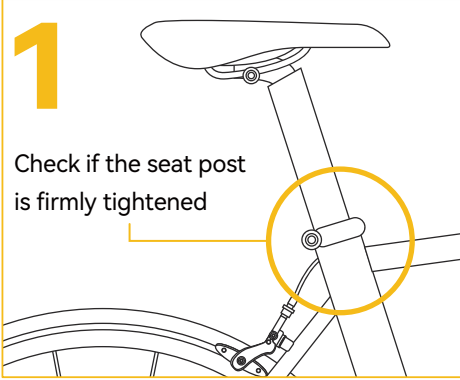

Make sure the seat post lock is securely tightened for a safe attachment.

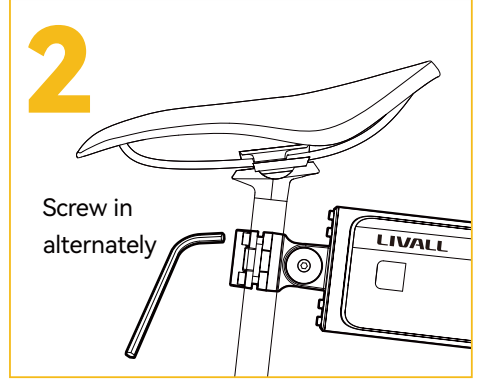

To guarantee the uniform forces, alternately screw in the clamp and unit into the seat post until they will not drop.

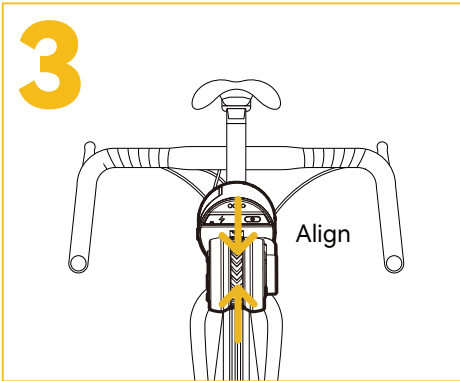

Align PikaBoost's tire with the rear tire of the bike.

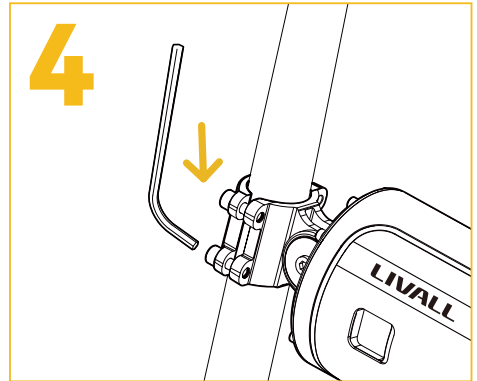

Fully tighten the screws on the unit with a wrench.

Note: If no bike/seat post replacement is needed, the bracket can be installed on the bike seat post without removing it.

Check the Fit Between the PikaBoost and the Bicycle

Once the PikaBoost is fully secured on the bicycle's rear tire, it is necessary to check the fit of the PikaBoost tire and rear tire of the bicycle to ensure safe riding.

Principle:

The higher the fit between the PikaBoost tire and the rear tire of the bicycle, the greater the friction force and the better the assisting effect.

Checking method:

Hold the middle bottom of the PikaBoost house with your hand, then lift it upwards.

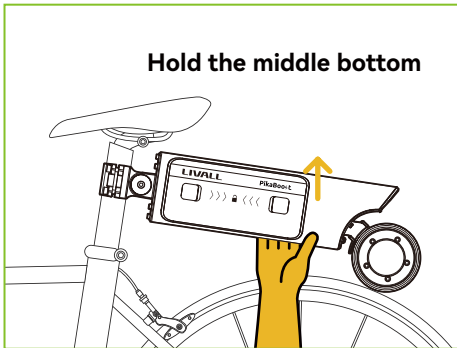

Solid Fit

When lifting the PikaBoost with your hand, the bicycle's rear tire will also be lifted.

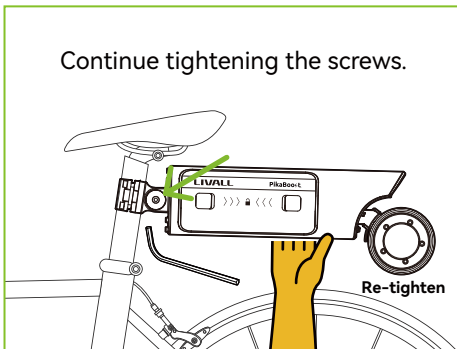

Weak Fit

When lifting the PikaBoost with your hand, the bicycle's rear tire does not make contact with it.

***Continue tightening the screw until it reaches a solid fit.**

Note: Before installing the device, please open the LIVALL Riding APP, enter the PikaBoost page, click "Install Calibration-Lift Up", and lift the PikaBoost wheel until it is automatically completed.

Install the PikaBoost

Before your first ride, it is important to calibrate the bike to ensure that the PikaBoost can provide assistance properly.

- **Calibration method:**

1. Park the bicycle on a level surface and make sure it is standing upright. Do not tilt the bike.

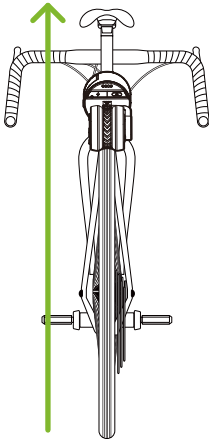

Note:
Do not tilt the bike during calibration.

2. Open the LIVALL Riding APP, enter the PikaBoost page, click "Install Calibration-Push Down", the wheel and the bicycle rear tire are automatically pressed and calibrated.

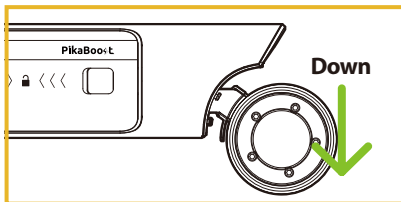
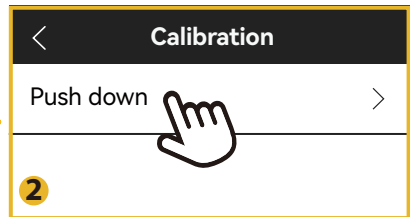
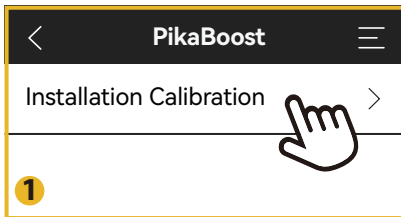

Recharging and Power Supply via PikaBoost

Recharging the PikaBoost

The provided battery case is shipped with only a partial charge. Do remember to charge your PikaBoost on your first ride for optimal performance.

Plug the provided Type-C cable into the Type-C port on the PikaBoost house/battery case and the charger (self-supplied), then plug the charger into an outlet to start charging.

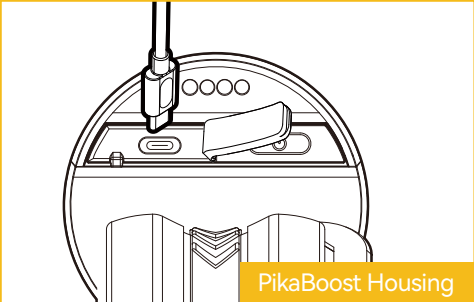

Via charging port on PikaBoost house.

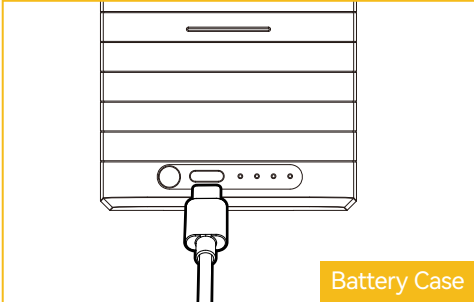

Via charging port on battery case.

When charging starts, the power indicator displays the following states:

100%	●	●	●	●
>75%	●	●	●	☀
>50%	●	●	☀	○
>25%	●	☀	○	○
0%	☀	○	○	○

On both PikaBoost and the battery case.

Power Supply with PikaBoost

The PikaBoost serves as a mobile power source to power your other devices.

Plug the provided Type-C cable into the Type-C port on the PikaBoost house/battery case and the charging port of the device that needs to be charged.

When the power supply starts, the power indicator displays the following states:

>75%	●	●	●	●
>50%	●	●	●	○
>25%	●	●	○	○
>5%	●	○	○	○
<5%	☀	○	○	○
0%	○	○	○	○

If the power indicator is blinking or not lighting up when supplying power, it indicates that the battery is running low.

Please stop the power supply action and recharge the PikaBoost in time to prevent the battery from draining.

The battery level is based on the power level indicated by the tail light of the PikaBoost machine.

⚠ WARNING!

1. If the PikaBoost battery is running low, it should be fully charged and then stored in a well-ventilated and dry place. This can prevent the battery from becoming ineffective due to prolonged battery drainage.
2. If the PikaBoost is left unused for a long period of time, the battery case needs to be recharged every three months. This can prevent the battery from becoming ineffective due to prolonged leakage.
3. For your safety, it is prohibited to disassemble or modify the battery.

Select and Switch Riding Modes

1. Standby

PikaBoost doesn't engage in assisting the bike or creating resistance.

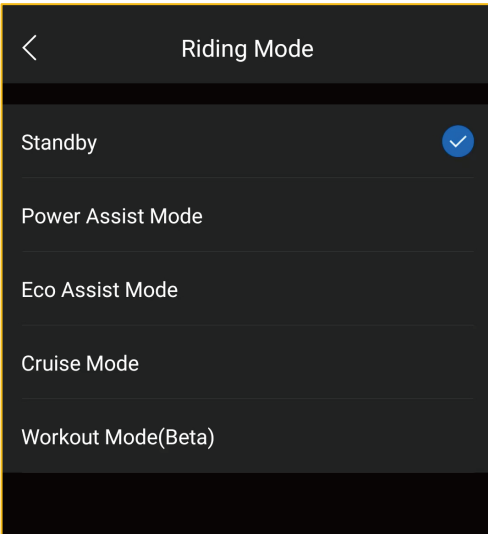

⚠ WARNING!

When in a non-riding state such as walking with the bicycle, it is important to switch the PikaBoost from riding mode to standby mode using the Bling remote controller or APP. This will avoid the risk of serious injury or death if the PikaBoost starts the motor to provide assistance to the bike during walking.

2. Power Assist Mode

Assistance is only provided during pedaling.

- To speed up, the assistance increases as the pedaling frequency is accelerated.

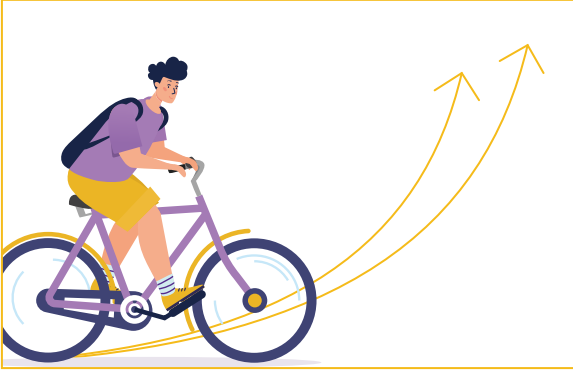

- To slow down, the assistance decreases as the pedaling frequency is reduced.



3. Eco Assist Mode

During riding, PikaBoost powers your bike when detecting uphill roads.

- No support or resistance on flat roads.
- Extra kinetic energy is converted to electrical energy during downhill roads.

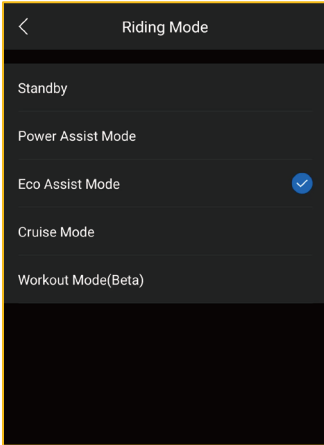

4.Cruise Mode

When PikaBoost detects a ride, it powers your bike and maintain the current speed, allowing you to enjoy riding at your current speed without pedaling.

- When you need to accelerate, you can increase the pedaling frequency or click the acceleration button of the remote control, and the PikaBoost power will increase accordingly.

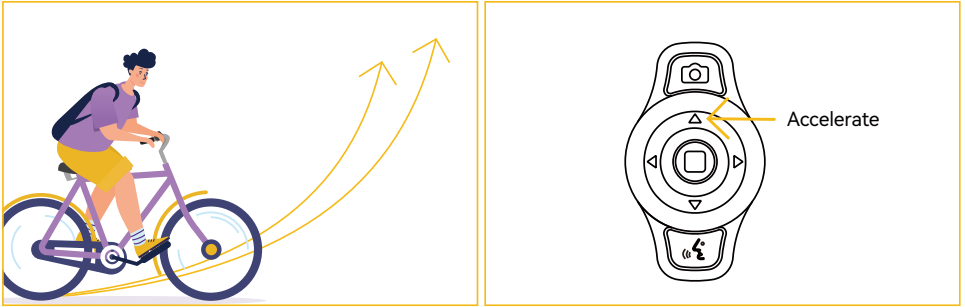

- When you need to slow down: grab the rear tire brake of the bicycle, the remote control detects its brake signal, and PikaBoost stops the power. Or click the deceleration button on the remote control, and the riding speed will decrease accordingly.

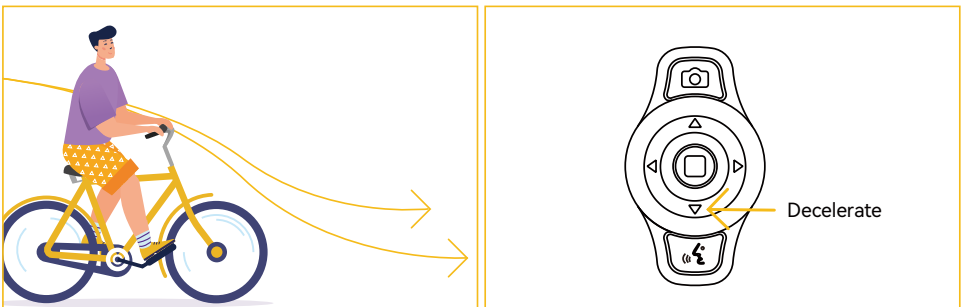

5. Workout Mode

PikaBoost doesn't assist your cycling, only adds resistance while converting kinetic energy into electric energy.

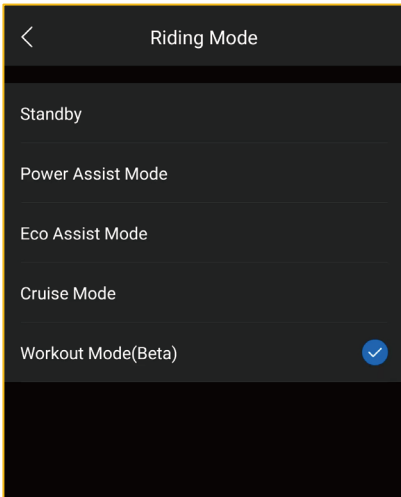

Switch the Riding Modes

1. Switch the riding modes via the APP

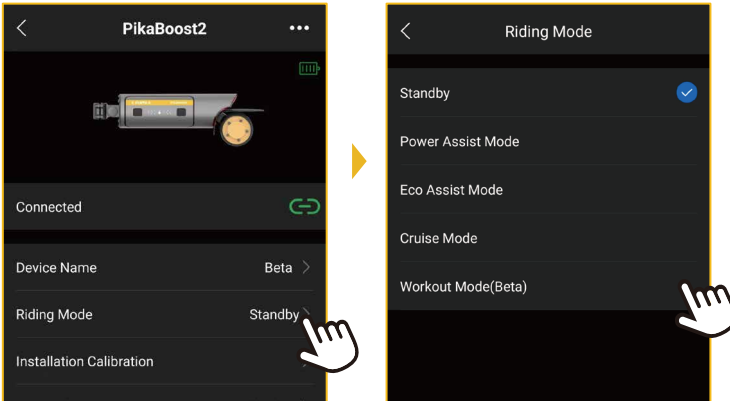

Enter the PikaBoost page on the APP and tap on the Riding Mode to select one.

2. Switch the riding modes via the remote controller

If the remote control is installed on the rear wheel brake handle of the bicycle and paired with PikaBoost successfully. You can switch between Power Assist mode and Cruise mode by double-clicking the confirmation button of the remote control.

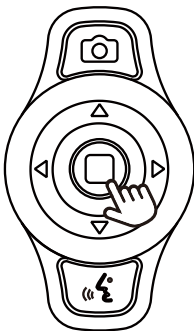

- Click:
Switch between standby status and current riding mode
- Double Click:
Switch between Power Assist mode and Cruise mode

Note: Cruise mode may not support between countries.

Note: Please refer to the content of Installation and Usage of the PikaBoost for detailed instructions.

Installation and Usage of the Remote Controller

Installation of the Remote Controller

If your country/region supports auto assist ride type, you can enjoy automatic riding after mounting the remote controller to the bike handlebar and matching it with your PikaBoost.

Functioning Principle

After successfully mounting the remote controller to the handlebar near the rear brake and the brake is pressed, the brake sensor keeps its distance from the magnet, so the sensor fails to detect the magnetic field and the receiver detects the braking signal, which will be transmitted to the matched PikaBoost to stop assistance. When you enjoy riding without pressing the brake, the brake sensor and the magnet stick together, thus the receiver detects the signal of normal riding and the PikaBoost provides assistance to the bike. Please install the remote controller according to this principle.

Part name

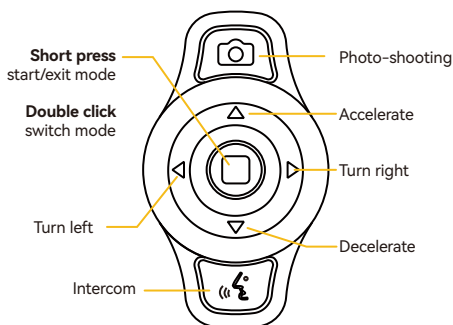
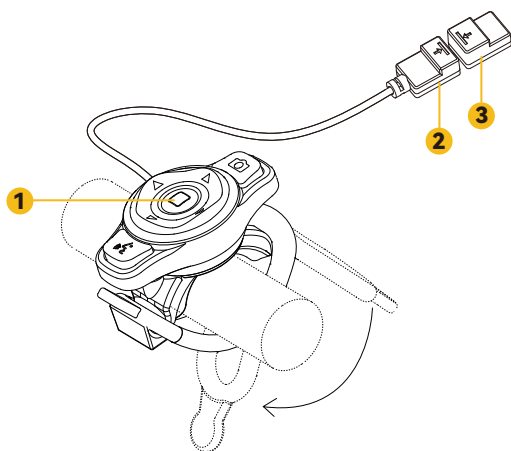

1 BR80 Indicator

2 Brake Sensor

3 Magnet

Matching Method

For the first use of the remote controller, you need to match the PikaBoost with the remote controller via the APP to ensure normal use.

Connecting to the BR series remote control

1 Connecting for the first time

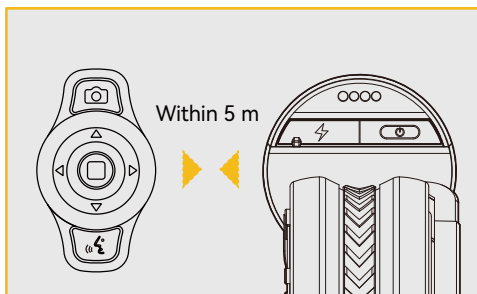

Turn on the Bling remote controller, which will connect to the PikaBoost automatically when it is within 5 m of the PikaBoost.



After successful connection, the indicator will blink two times in quick succession. After successful connection, press the " L " or " R " button of the remote to control the turn signal light of the PikaBoost.

2 Connecting to a new remote control

(in case the original remote control gets lost or damaged):



Keep the active Bling remote controller near the control module of the PikaBoost.

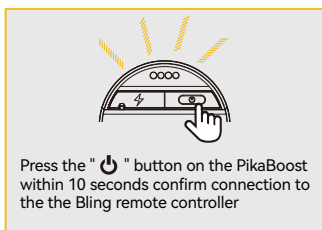

The LED taillight will blink once per second, indicating that Bling remote controller needs be connected.

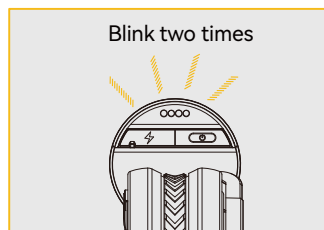

After successful connection, the indicator will blink two times in quick succession.

Connect to both the helmet and PikaBoost simultaneously.

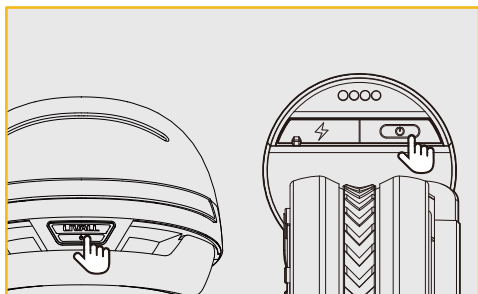

1. Turn on both the helmet and PikaBoost.

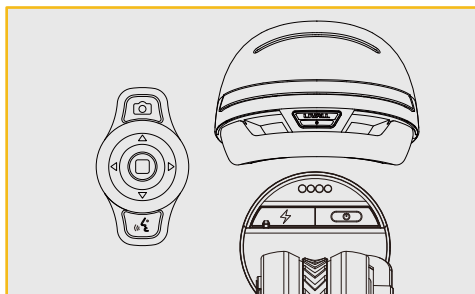

3. Bring the remote control close to the helmet and PikaBoost, then press any button on the remote control to activate it.

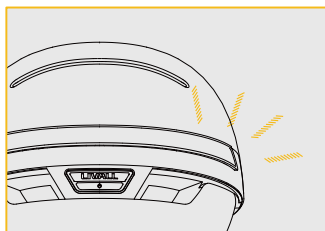

3. Press the left or right direction button to confirm if you can control the lights simultaneously.

Mounting Method

Your package contains the following items:

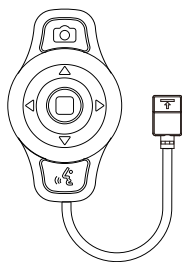

Bling Remote Controller



Magnet



Rubber Band



3M sticky pads

- 1 Mount the receiver to the handlebar next to the rear brake with the supplied rubber band.

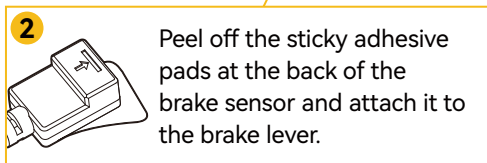
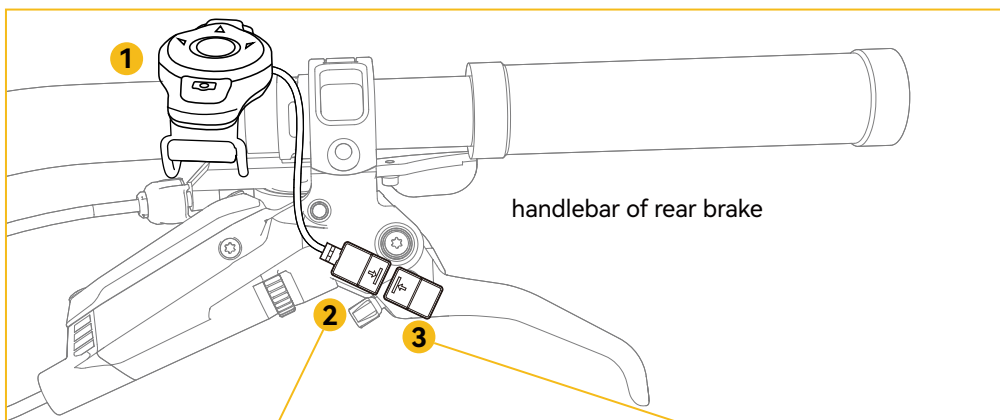

Peel off the sticky adhesive pads at the back of the brake sensor and attach it to the brake lever.

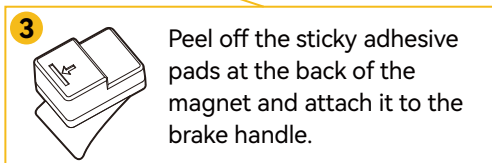

Peel off the sticky adhesive pads at the back of the magnet and attach it to the brake handle.

Note: Find a suitable place to attach the brake sensor and magnet as the style of the handlebar differs.

⚠ WARNING!

Before each ride, be sure to check the fixed situation of the brake sensor and magnet. If they are loosened, refix them to a suitable place, or it may exist a potential danger during riding.

Check the Mounting Position

It is necessary to check whether the mounting position is the best one after attaching the remote controller to the handlebar. If the position is not sensitive enough to detect the brake signal, you need to adjust the position of the brake sensor and magnet until it reaches the most sensitive position.

Checking method:

Press the brake repeatedly and watch the lighting of the brake indicator and tail light.

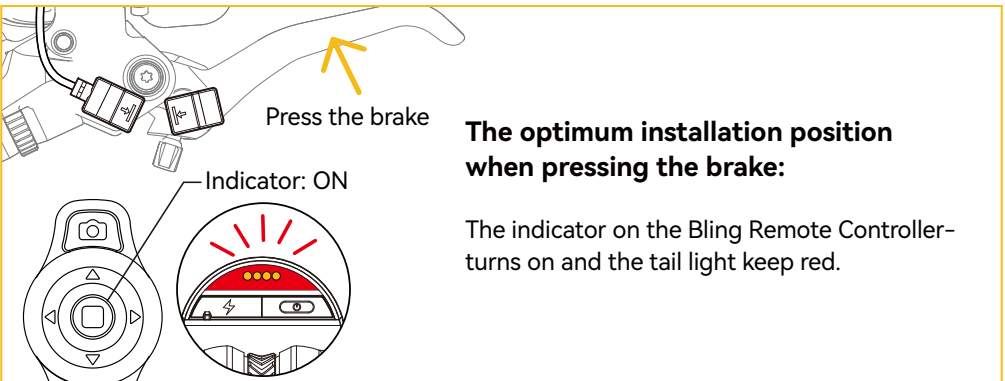
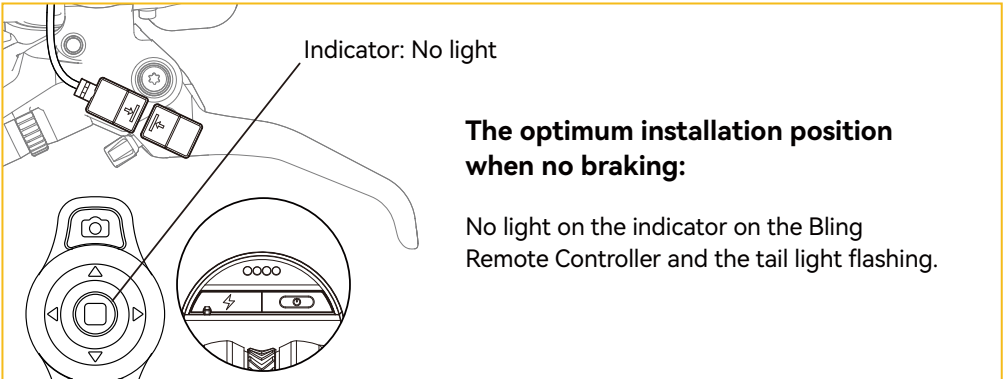

Note:

1. If you need to use the cruise mode, make sure the remote controller is connected normally before riding; be sure to check that Pikaboot is in the braking state when you grab the brake handle, and the state is released when you release the brake handle; make sure that the installation position is the most sensitive position.

2. As the stickiness of the sticky adhesive pad will gradually deteriorate with use. For your riding safety, please replace the adhesive pad on the back of sensor and magnet in time. If the supplied 3M sticky pads are used up, you can purchase double sided tape by yourself, and the 3M strong adhesive is recommended.

Usage

After successfully mounting the paired remote controller to the handlebar, you can switch the riding modes by single pressing or double-pressing the button on the remote controller.

Riding Modes	Power Button	Beep from Brake Controller: For countries/regions that support Cruise Mode	Beep from Brake Controller: For countries/regions that do not support Cruise Mode
Standby	Single press	“Beep” for two seconds in low frequency	“Beep” for two seconds in low frequency
Power Assist Mode	Double press	One “beep” in high frequency	One “beep” in high frequency
Cruise Mode		Four “beep” in high frequency	Unavailable

⚠ WARNING!

When in a non-riding state such as walking with the bicycle, it is important to switch the PikaBoost from riding mode to standby mode using the Brake Controller or APP. This will avoid the risk of serious injury or death if the PikaBoost starts the motor to provide assistance to the bike during walking.

Battery Replacement

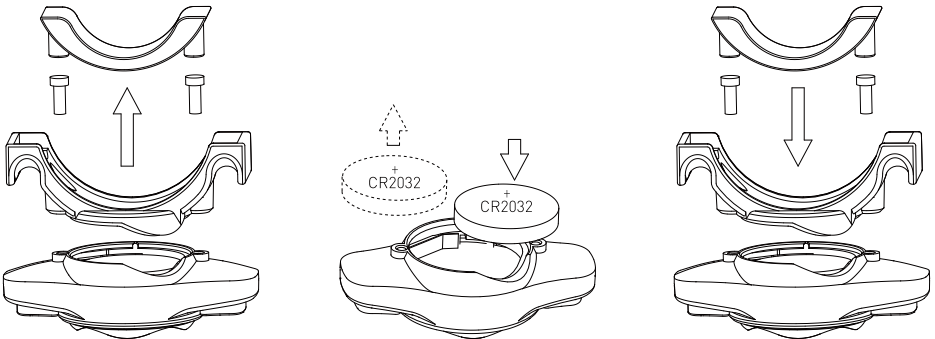

Safety Information

1. Keep the product dry. Do not use the product in places with dust, moisture, or dirt to avoid internal circuit malfunctions.
2. Do not use this product during thunderstorms. Thunderstorms may cause equipment malfunctions or motor hazards.
3. Do not use the PikaBoost to supply power when rainy riding. Dry your USB-C charging port before charging if there are water stains.
4. Use this product within the charging temperature range of 0°C–40°C and the discharging temperature range of -10°C to 40°C. Store the device and its accessories within the temperature range of -10°C to 40°C. Extreme temperatures may cause equipment malfunctions.
5. When charging the device, the power socket should be installed near the device and easily accessible. When charging is complete or not needed, please disconnect the charger from the device and unplug it from the power socket.
6. If the device needs to be charged via a USB port, make sure the USB port has the USB-IF logo and meets the relevant specifications of USB-IF.
7. Keep the device and battery away from sources of fire, high temperatures, and direct sunlight.
8. Do not throw the battery into the fire. Do not disassemble, drop, crush, or modify the battery. Do not insert foreign objects or puncture the battery.
9. Do not immerse the battery in water or other liquids. Avoid external impacts, pressure, or severe collisions on the battery to prevent leakage, overheating, fire, or explosion.
10. Dispose of the device, battery, and other accessories according to local regulations. Do not treat them as household waste. Improper disposal of batteries may lead to explosions.
11. The device and its accessories may contain small parts. Please keep them out of the reach of children. Children may accidentally damage the device and its accessories or swallow small parts, leading to choking or other dangers.

Warranty Policy

1. Basic Information

- For product malfunctions, please contact LIVALL customer support directly. For more details, visit livall.com or email pikaboost@livall.com.
- The warranty period of the product is subject to the warranty period announced by LIVALL on the official website.

2. Warranty Regulations

- The warranty period for the product starts from the shipping date plus the grace period.
- Repaired products continue to enjoy warranty services within the warranty period. If the warranty period is less than three months from the end, the replaced parts have a three-month warranty from the date of replacement. Replaced parts belong to the manufacturer, and appropriate costs may be charged when necessary.

3. Non-warranty Regulations

- Non-hardware-based technical problems.
- Products without the LIVALL logo. Non-LIVALL accessories or user-replaced accessories which have not been purchased from LIVALL or a LIVALL authorized seller.
- Cleanliness or regular maintenance of the product.
- Consumable materials (such as natural consumption, wear and tear, and aging of the housing, plug-in parts, and battery cells), malfunction or damage caused by incorrect installation, operation (such as mixing battery cells when replacing them, etc.), or use in an operating environment other than that specified for the product (such as excessively high or low temperature, excessive humidity or dryness, high altitude, unstable voltage or current, etc.).
- Damage caused by accident, abuse (including exceeding the working load), or improper use.
- Damage caused by improper storage (such as rodent damage, and liquid infiltration).
- Malfunctions or damage caused by unauthorized disassembly and repair, unauthorized modification, or abuse.
- Damage caused by repairs not performed by a LIVALL-authorized repair center.

Safe Operating Tips

- In non-riding situations, always switch the PikaBoost from riding mode to standby mode by using the remote controller or APP. This prevents PikaBoost from providing assistance to the bicycle by starting the motor while walking, which could pose a risk of serious injury or death.
- Due to the added weight of PikaBoost on bicycles, it is not recommended to use this product for large jumps or stunts of any kind. The manufacturer is not responsible for any accidents, injuries, or property damage caused by the use or misuse of PikaBoost E-bike conversion kit by riders, including any damage incurred from off-road use.
- Failure to properly install, ensure compatibility, operate or maintain any components or accessories may result in serious injury or death.
- Before using the PikaBoost, users must select the corresponding country/region on the APP to obtain legal top speed and a suitable riding mode. It is important to ride at a suitable speed based on the usage area, riding conditions, and user experience level.
- Any non-original modifications or alterations made to your PikaBoost may void the warranty and result in an unsafe riding experience.
- As a user, you have the primary responsibility for operating PikaBoost safely. Always stay alert and aware to avoid any risky behaviors, and comply with traffic regulations.
- To prevent unauthorized use, always remove the battery pack from PikaBoost on your bicycle and store it in a safe place when not in use. Failing to prevent unauthorized use of your PikaBoost may result in serious injury or even death to others.
- Never operate your PikaBoost while drinking alcohol or using drugs, including prescription or over the counter medications.
- If you have any disabilities or impairments such as visual impairment, hearing impairment, physical impairment, cognitive/language impairment, and/or epilepsy, please consult your doctor before using the PikaBoost for cycling.
- Do not allow children to use PikaBoost without supervision. Make sure children maintain a safe distance from PikaBoost at all times while using it.

Disclaimer: THE MANUFACTURER, SELLER, AND DISTRIBUTORS ARE NOT RESPONSIBLE FOR ANY ACCIDENTS, INJURIES, OR PROPERTY DAMAGE CAUSED BY IMPROPER USE, OPERATION, OR RIDING.

Please note that this statement is intended to remind you to use PikaBoost and the power battery (lithium battery) correctly and safely to reduce potential risks and damages.

By using this product, you agree to comply with all the terms and conditions stated in this statement and take full responsibility for the risks and liabilities associated with using the PikaBoost and power battery (lithium battery).

We are not responsible for any losses or injuries caused by improper use of the product and/or battery, and we reserve the right to modify, interpret, and publish this statement on our official website.

Users must comply with the latest version of the operating instruction and safe operation tips.

Local Laws

The regulations regarding the use and operation of E-bike conversion kits may vary depending on the country, state/province, and city of residence. In many cases, the regulations for using E-bike conversion kits are the same as those for regular bicycles.

However, each jurisdiction may have laws regarding permits and regulations for E-bike conversion kits, areas where they can be ridden, minimum riding age, or required equipment (such as helmets).

Riders are responsible for understanding the local regulations for using such products and complying with them.

Warning

This product is equipped with a battery pack containing 18 lithium battery cells. To ensure safety and performance, please note the following:

NOTE: This equipment has been tested and found to comply with the limits for a Class B digital device, pursuant to part 15 of the FCC Rules. These limits are designed to provide reasonable protection against harmful interference in a residential installation. This equipment generates, uses and can radiate radio frequency energy and, if not installed and used in accordance with the instructions, may cause harmful interference to radio communications. However, there is no guarantee that interference will not occur in a particular installation. If this equipment does cause harmful interference to radio or television reception, which can be determined by turning the equipment off and on, the user is encouraged to try to correct the interference by one or more of the following measures:

- Reorient or relocate the receiving antenna.
- Increase the separation between the equipment and receiver.
- Connect the equipment into an outlet on a circuit different from that to which the receiver is connected.
- Consult the dealer or an experienced radio/TV technician for help. Changes or modifications not expressly approved by the party responsible for compliance could void the user's authority to operate the equipment.

This device complies with Part 15 of the FCC Rules. Operation is subject to the following two conditions:

(1) this device may not cause harmful interference, and (2) this device must accept any interference received, including interference that may cause undesired operation.

Operating Frequency Range	The maximum RF Output Power
Bluetooth BLE 2402-2480MHz	-3.30dBm

Hereby, LIVALL Tech Co., Ltd. declare that the radio equipment type Pikaboost is compliance with Directive 2014/53/EU.

The full text of the EU declaration of conformity is available at the following internet address: <https://livall.com/pages/product-documents>.

FCC ID: 2AEKF-L4P01



Contact us

Website: www.livall.com

E-mail: user@livall.com

